

Hughes 9410 Mobile Satellite Terminal

Installation Guide

H67706
Revision D
April 4, 2024

11717 Exploration Lane, Germantown, MD 20876

Phone (301) 428-5500 Fax (301) 428-1868/2830

Copyright © 2022, 2023, 2024 Hughes Network Systems, LLC

All rights reserved. This publication and its contents are proprietary to Hughes Network Systems, LLC. No part of this publication may be reproduced in any form or by any means without the written permission of Hughes Network Systems, LLC, 11717 Exploration Lane, Germantown, Maryland 20876.

Hughes Network Systems, LLC has made every effort to ensure the correctness and completeness of the material in this document. Hughes Network Systems, LLC shall not be liable for errors contained herein. The information in this document is subject to change without notice. Hughes Network Systems, LLC makes no warranty of any kind with regard to this material, including, but not limited to, the implied warranties of merchantability and fitness for a particular purpose.

Trademarks

HUGHES and Hughes Network Systems are trademarks of Hughes Network Systems, LLC. All other trademarks are the property of their respective owners.

Contents

Understanding safety alert messages	4
Chapter 1	
Introduction	6
1.1 Hughes 9410 mobile satellite terminal.....	6
1.1.1 Terminal physical dimensions	6
1.1.2 Package Material and accessories available.....	7
1.1.3 Accessories available	7
1.1.4 Power port.....	8
1.1.5 System power requirements	8
1.1.6 SIM card.....	9
Chapter 2	
Custom cable connections.....	10
2.1 Adding an RJ45 connector to the power cable.....	10
Chapter 3	
Vehicular installation.....	12
3.1 Basic installation procedure	12
3.2 Installation notes	12
3.3 Permanent mount installation.....	12
3.3.1 Installation.....	12
3.3.2 Drainage of the antenna.....	14
3.3.3 Cleaning	15
3.4 Magnetic mounting (optional).....	15

Understanding safety alert messages

Safety alert messages call attention to potential safety hazards and tell you how to avoid them. These messages are identified by the signal words DANGER, WARNING, CAUTION, or NOTICE, as illustrated below. To avoid possible property damage, personal injury, or in some cases possible death, read and comply with all safety alert messages.

Messages concerning personal injury

The signal words DANGER, WARNING, and CAUTION indicate hazards that could result in personal injury or in some cases death, as explained below. Each of these signal words indicates the severity of the potential hazard.



WARNING indicates a potentially hazardous situation which, if not avoided, could result in death or serious injury.



CAUTION indicates a potentially hazardous situation which, if not avoided, could result in minor or moderate injury.

Messages concerning property damage

A NOTICE concerns property damage only.



NOTICE is used for advisory messages concerning possible property damage, product damage or malfunction, data loss, or other unwanted results—but *not* personal injury.

Safety symbols

The generic safety alert symbol



calls attention to a potential personal injury hazard. It appears next to the DANGER, WARNING, and CAUTION signal words as part of the signal word label. Other symbols may appear next to DANGER, WARNING, or CAUTION to indicate a specific type of hazard (for example, fire or electric shock). If other hazard symbols are used in this document, they are identified in this section.

Chapter 1

Introduction

The purpose of this guide is to instruct personnel on how to install the Hughes 9410 mobile satellite terminal in a vehicle.

WARNING

This product must be installed by authorized service personnel.

-  Damages resulting from the failure to conform to the instructions found herein, as well as standard installation practices, will be the responsibility of the installer.

1.1 Hughes 9410 mobile satellite terminal

The 9410 is a fully integrated land mobile class 11 satellite terminal with Ethernet and WLAN interfaces.



Figure 1. 9410 mobile satellite terminal (integrated modem and antenna)

The Hughes 9410 has a single connector for power and Ethernet (no cable included with the terminal). There are two versions of the 9410, each with different interfaces. See the variants listed in [Table 1](#).

Table 1. 9410 variants

9410 Version	Hughes P/Ns	Interfaces
9410LW	3501431-0003	Ethernet, WLAN
9410L	3501431-0002	Ethernet

1.1.1 Terminal physical dimensions

Size: 270 mm x 150 mm

Weight: 3.0 kg

1.1.2 **Package Material and accessories available**

The 9410L or 9410LW is shipped in a box containing only the mobile satellite terminal, with no accessories.

1.1.3 **Accessories available**

Various accessories like data and power cables are available in the Hughes catalog.

Several accessories (ready-made cables, custom cables, connectors and mounting hardware) are available for connecting the 9410. See the details below.

1. Power and data cable, blunt wire, 5 m (P/N: 3501314-0002)
2. Power and data cable, blunt wire, 10 m (P/N: 3501314-0003)



3. Power and data cable, cigarette lighter plug and RJ45 socket, 5 m (P/N: 3501314-0004)



4. Custom power and data cable, 100 m (P/N: 9509897-0001)
5. Magnetic Mounts (P/N: 3501152-0002)



6. RJ45 Wiring Block (P/N: 9510250-0002)



7. Mating power and data connector, bare (P/N: 9509554-0001)



Please refer to the Hughes catalog for further details: bgan.hughes.com

1.1.4 Power port

The power port is the connection from the power supply (vehicle battery or another 12 VDC power source) to the satellite terminal. The power cable has a +V power line, an ignition sense line, and a –V power line.

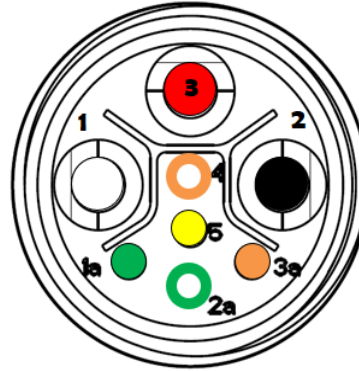

Figure 2. 9410 power and data port connector pinout

Table 2. Pinout details

Pin	Wire Color	Description
1	White	Remote switch/ Ignition Sense
2	Black	GND
3	Red	PWR 12 VDC
1a	Green	ENET-RXN
2a	White/green	ENET-RXP
3a	Orange	ENET-TXN
4	White/orange	ENET-TXP
5	Yellow	Not used

1.1.5 System power requirements

There is one power connection on the terminal. This must be connected to a 12 VDC power supply.

Power requirements and consumption are listed in [Table 3](#).

Table 3. System power requirements

Voltage Input Minimum	Voltage Input Maximum	Power Draw Idle	Power Draw Maximum
9 VDC	20 VDC	15 W	50 W

1.1.6 SIM card

The satellite terminal requires an Inmarsat SIM to be installed.

In order to install the SIM, unscrew the six M3 screws using a Torx 10 screwdriver and carefully lift up the radome, as shown in [Figure 3](#) on page 9. Please note that the torque value for this type of screw is 0.6–0.8 Nm.

Note: Before removing the radome please make sure the terminal is disconnected from the power.

Insert the SIM (supplied by the dealer) into the SIM card holder with the metal contacts facing down. You will hear a click once the SIM card is correctly inserted. The SIM card will protrude slightly from the metal casing, as shown in [Figure 4](#).

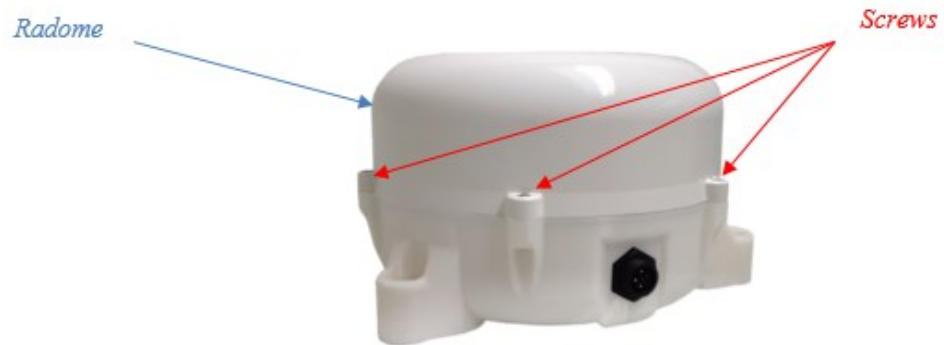

Figure 3. Removing the radome

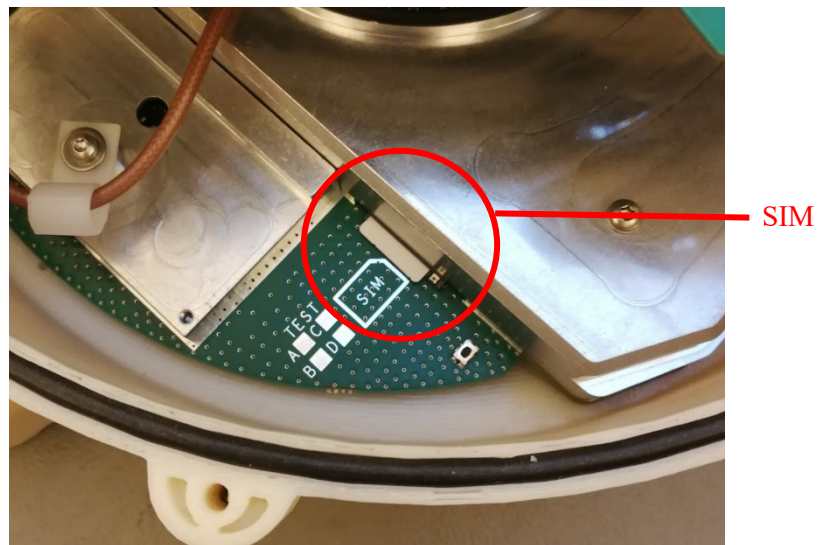

Figure 4. Installing the SIM card

Carefully replace the radome and reinstall the screws with a torque setting of 0.6–0.8 Nm.

Custom cable connections

2.1 Adding an RJ45 connector to the power cable

Follow the instructions in [Table 4](#) to add an RJ45 connector to the power and data cable.

Table 4. Power cable and RJ45 options

Power Cable Type	Power Cable Hughes P/N	RJ45 Connector Hughes P/N
Power and data cable, blunt wire, 5 m	3501314-0002	9510250-0002
Power and data cable, blunt wire, 10 m	3501314-0003	
Power and data cable, blunt wire, 100 m	9509897-0001	

1. Strip the power cable to expose the internal wires.
2. Connect the RJ45 wiring block to the power cable using a straight-through connection. Reference [Figure 5](#) and [Table 5](#) on page 11 for the power and RJ45 connector pinouts.

Internal Wires Power Cable

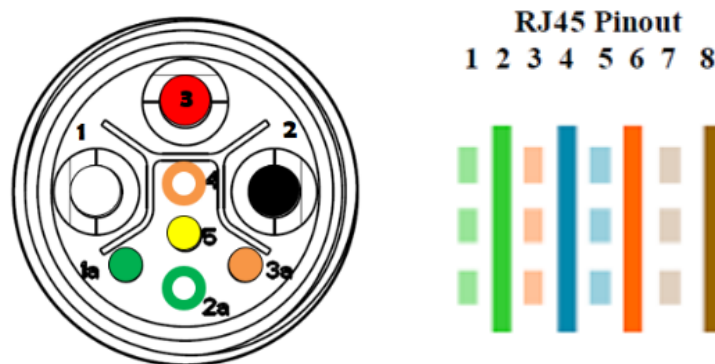

Figure 5. Power cable: RJ45 connection details

Table 5. Power cable: RJ45 connection details

Power Cable	Power Cable Wire Color	Power Cable Wire Function	Connection Type	RJ45 Pinout
1a	Green	Ethernet RX-	Straight-Through cable	6
2a	White/Green	Ethernet RX+	Straight-Through cable	3
3a	Orange	Ethernet TX-	Straight-Through cable	2
4	White/Orange	Ethernet TX+	Straight-Through cable	1
5	Yellow	Not used	No connection	
1	White	Remote switch/ Ignition Sense	No connection, just strip and tin the wire ends	
2	Black	Ground	No connection, just strip and tin the wire ends	
3	Red	Power +12 VDC	No connection, just strip and tin the wire ends	

- Strip and tin the remaining wires (power, ground, remote switch wire ends) of the power cable.

Note: The yellow wire of the power cable is for future use, so it can be left with no connection

- Use tie wraps for strain relief if necessary (see [Figure 6](#)).
- The remote switch/ignition can be used for vehicles to ensure that power is only supplied to the terminal when the Ignition switch is on. If the remote switch/ignition wire is not used, then Pin 1 and Pin 3 need to be connected or Pin 1 needs to be connected to the power source.

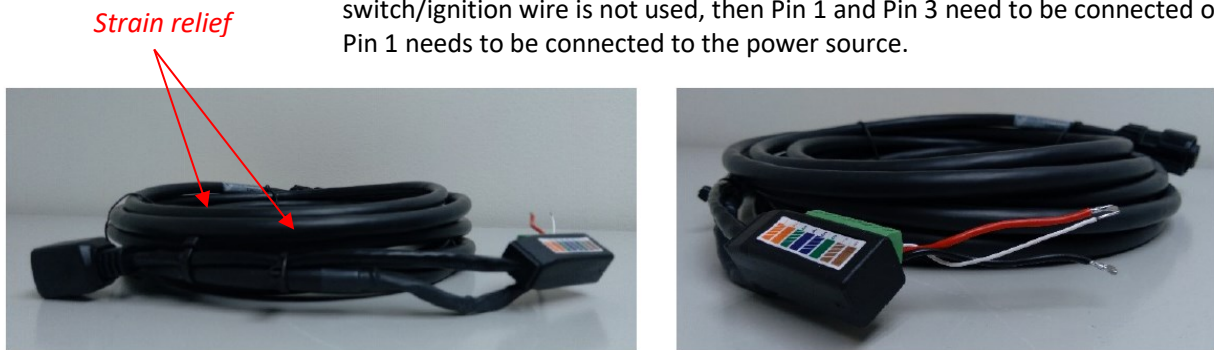

Figure 6. Power cable connected to an RJ45: Final results

Vehicular installation

3.1 Basic installation procedure

The basic installation procedure is as follows:

1. Decide where you are going to install the satellite terminal.
2. Determine the cable length required for the power installation.
3. Install the satellite SIM card.
4. Permanently install using the provided mounting kit or install three magnetic mounts for vehicle roof mounting (optional).
5. Connect the power and data cables to the terminal.
6. Connect the terminal to the user equipment.

3.2 Installation notes

1. Whenever routing cable through holes drilled in metal or through bulkheads, use grommets and RTV sealant to weatherproof all holes drilled on the outside of the vehicle.
2. Use cable ties every 300–450 mm
3. The main power line must be connected to a fused 12 VDC power source. A 10 A fuse is required in the source to protect against shorts in the cabling. If connecting to a circuit in the fuse box that is already in use, ensure that the circuit can supply the unit with at least 6 A.
4. Route and connect the white ignition sense wire to a switched 12 VDC source.
5. Always provision internal wiring with a drip loop.

3.3 Permanent mount installation

3.3.1 Installation

When permanently installing the terminal on vehicles, some important guidelines must be followed to ensure long and trouble-free operation.

1. Always install the terminal so that it is in a horizontal position, even if the surface on which it is installed on e.g., the roof of a vehicle is not horizontal.

The antenna has drainage holes at the bottom.

2. Always install the terminal so that the clearance between the drainage holes at the bottom of the antenna and the mounting surface is no less than 5 mm and preferably 10 mm.

The hole pattern needed to permanently mount the terminal is shown in [Figure 8](#) (see installation guidelines for mounting advice).

Not following the above guidelines will void the warranty of the antenna. If in doubt, please consult Hughes at mobilesatellitesupport@hughes.com.

3. In order to fulfill the criteria 1 and 2 above, use the supplied set of mounting hardware as shown in Figure 7.

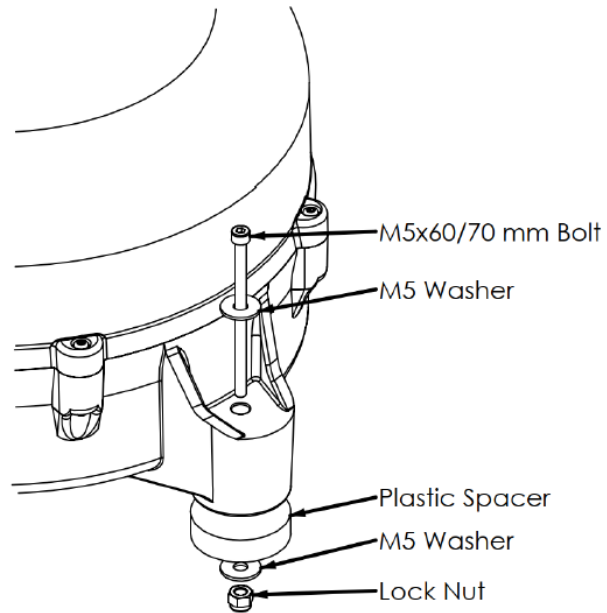

Figure 7. 9410 mounting hardware

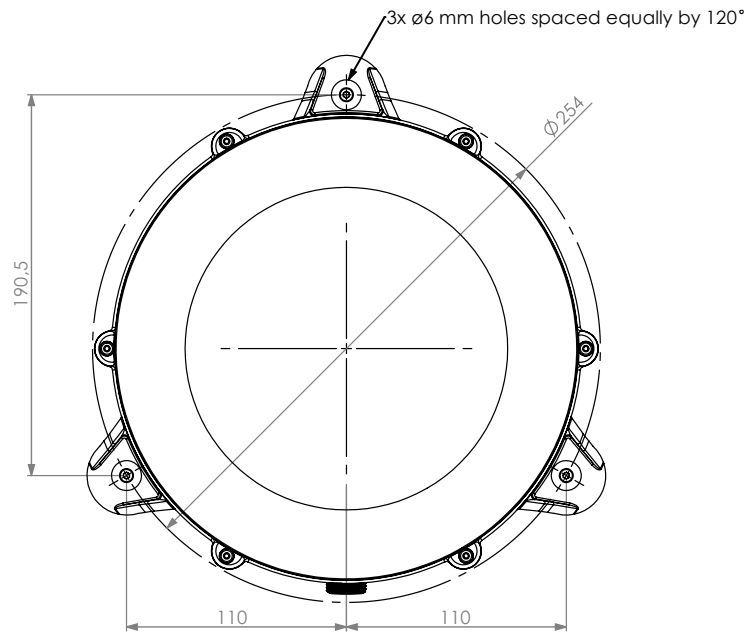

Figure 8. 9410 mounting hole pattern

The installation kit included with the antenna contains two sets of M5 bolts (60mm and 70mm), stainless steel washers, plastic spacers and lock nuts. The included plastic spacers allow the antenna to have sufficient clearance between the bottom of the radome and the mounting surface. The two different bolt lengths included are used for different mounting surface thickness, see [Figure 9](#) and [Figure 10](#).

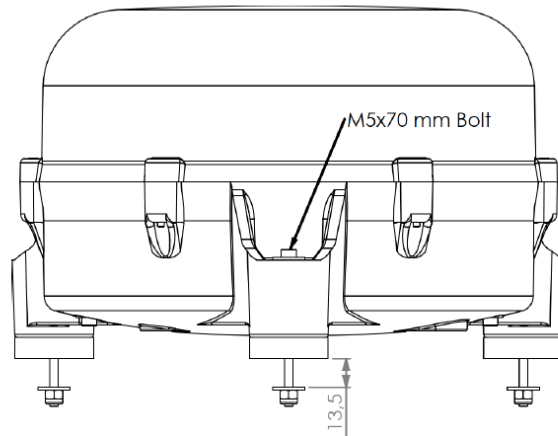

Figure 9. Installation using a M5x70 mm

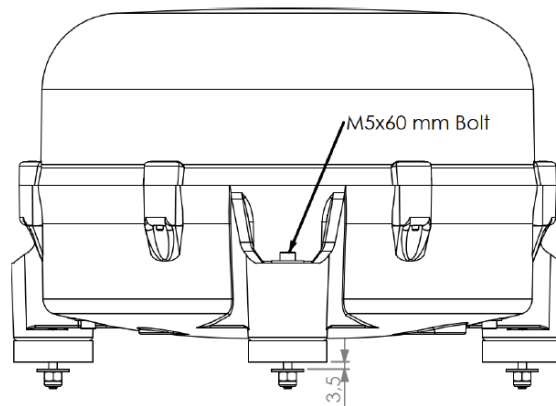

Figure 10. Installation using a M5x60 mm bolt

A dedicated magnet mounting kit (P/N: 3501152-0002) can be used when installing the antenna onto a car roof. Refer to [Section 3.4](#) of this document for further information.

3.3.2 *Drainage of the antenna*

A simple drainage mechanism is used in the bottom of the unit to provide venting and drainage of any condensation inside the radome. Correct function of the

drainage system will only be ensured by following criteria mentioned in Section 3.3.1.

3.3.3 *Cleaning*

The antenna can be cleaned and washed together with the vehicle (hosing down or driving through a washing tunnel). When using a pressure washer, do not direct the jet towards the antenna from short distance. Avoid pressure washing at maximum pressure; the sealing gasket may not withstand such high-pressure jet.

Never direct a water jet towards the drainage holes at the radome bottom. Water may be forced up the drainage channel.

3.4 Magnetic mounting (optional)

Three magnetic mounts (P/N: 3501152-0002) are optional for the terminal installation.

Parts list for 3501152-0002 magnet mount installation for vehicle antenna		
Part number	Quantity	Description
M40-10035-2	3	Magnet ø88 ø5,5
M60-10006-2	12	Rubber washer ø18/ø6x3 mm EDPM
M90-10128	3	M5 Washer
M90-10155	3	M5 Top locknut
M90-10269	3	Bolt M5x45 DIN6912 A4

The magnetic mount consists of three high-intensity magnets with rubber coating.

First put the bolt through the magnet. The hole in the magnet has a recess on one side - ensure the bolt head fits into this recess in the magnet. Next, place two rubber washers on each bolt. Put the bolt through the hole on one of the antenna's three "ears". Then place two rubber washers on each bolt above each "ear", the stainless-steel washer above the upper washer and the M5 protective nut on top. Torque until height is 37mm / 1.46", as shown in Figure 11.

Now place the antenna with magnets on the roof of the vehicle.

When installing the antenna cable, it is important to protect it against moisture – using self-amalgamating tape wrapped around the coaxial connector. Also, be careful with the cable run from the antenna and secure it at short intervals. An unsupported length of cable will vibrate when driving and could over time develop a bad connection.

Dismounting:

Grab the antenna near one of the magnets and lift up. When one magnet is loose, the other two are easy to "pop off".

In some situations, the magnetic force is so large that it may be necessary to unscrew the antenna first and remove the magnets separately.

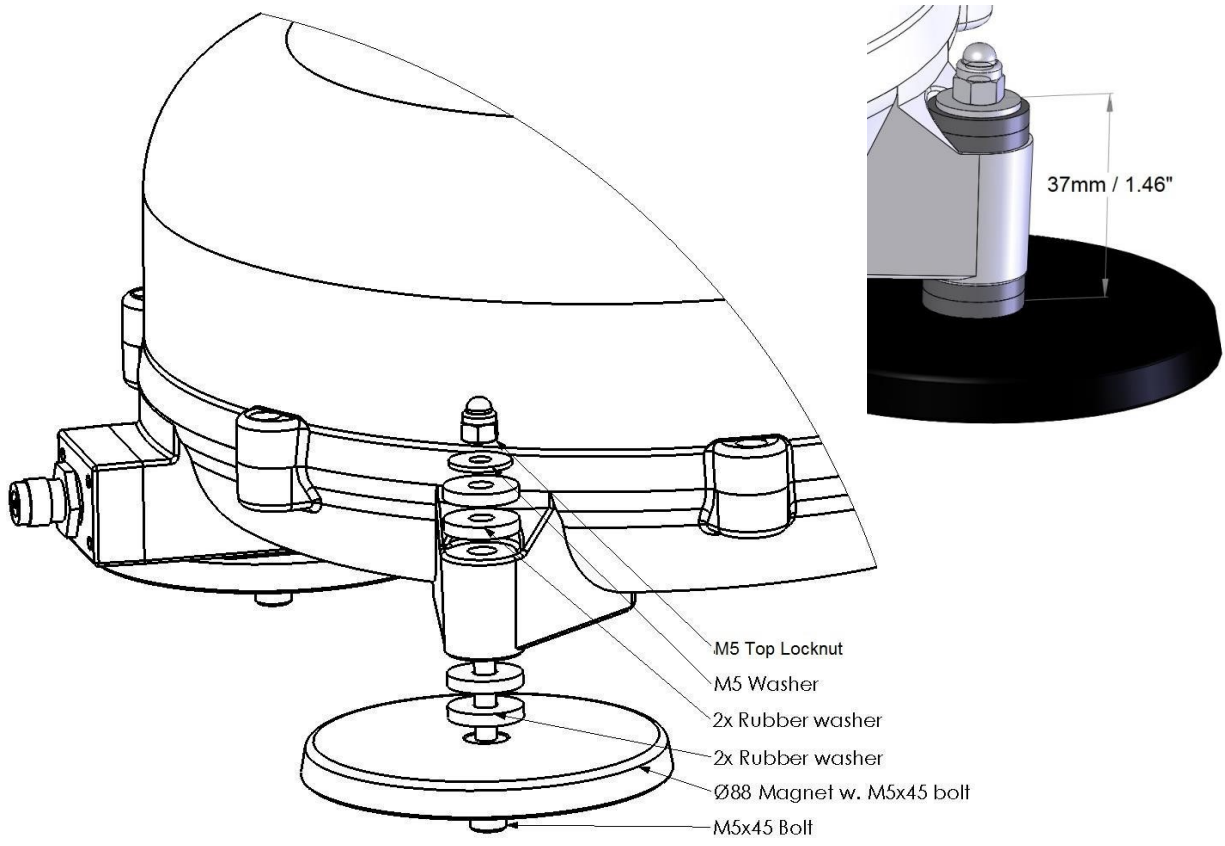

Figure 11. Magnetic mount installation