

**HUGHES**<sup>®</sup>



# **Hughes 9300 Series**

# **Mobile Satellite Terminal**

## **Installation Guide**

1038494-0001  
Revision E



### **Copyright © 2011 Hughes Network Systems, LLC**

All rights reserved. This publication and its contents are proprietary to Hughes Network Systems, LLC. No part of this publication may be reproduced in any form or by any means without the written permission of Hughes Network Systems, LLC, 11717 Exploration Lane, Germantown, Maryland 20876.

Hughes Network Systems, LLC has made every effort to ensure the correctness and completeness of the material in this document. Hughes Network Systems, LLC shall not be liable for errors contained herein. The information in this document is subject to change without notice. Hughes Network Systems, LLC makes no warranty of any kind with regard to this material, including, but not limited to, the implied warranties of merchantability and fitness for a particular purpose.

### **Trademarks**

Hughes and Hughes Network Systems are trademarks of Hughes Network Systems, LLC. All other trademarks are the property of their respective owners.

## Contents

---

Introduction.....	5
Indoor Unit (IDU).....	6
Power Port.....	7
Ethernet Port.....	7
RJ 45 Ethernet Port with Power over Ethernet (PoE).....	7
ISDN Port.....	8
RJ11 Ports.....	8
Antenna Port.....	8
USB Port.....	9
WLAN Port.....	9
SIM Card.....	9
System Power Requirements.....	10
Fuse.....	10
Power Cable.....	11
Standard Cable Connections.....	11
Ignition Sense (White Wire).....	11
Chassis Grounding.....	11
Basic Installation Procedure.....	13
Vehicular Installation.....	13
Installation – General.....	13
Common IDU Mounting Information.....	14
The Antenna Outdoor Unit (ODU).....	16
Antenna Cable Lengths and Types.....	17
Installing the Antenna.....	17
Land Mobile Antenna.....	19
Magnetic Mounting (Optional).....	19
Magnetic Mount Installation.....	19
Dismounting the Magnetically Mounted Antenna.....	20
Permanent Mount Installation.....	20
Drainage of the antenna.....	21
Extreme Conditions.....	22

## Figures

---

Figure 1 – IDU Common IDU (left), Class 10 ODU (middle), and Class 11 (right) .....	5
Figure 2 – Indoor Unit (IDU).....	6
Figure 3 – Power Port Pin Out.....	7
Figure 4 – Ethernet Port Pin Out.....	7
Figure 5 – ISDN Port Pin Out.....	8
Figure 6 – RJ11 Port Pin Out.....	8
Figure 7 – Inserting SIM Card in the SIM Card Holder .....	10
Figure 8 – System Power Requirements.....	10
Figure 9 – Power Cable Pin Out .....	11
Figure 10 – Grounding Nut.....	12
Figure 11 – Common Indoor Unit Mounting Dimensions .....	14
Figure 12 – Class 10 Antenna ODU Ø477 mm X 153 mm Height .....	16
Figure 13 – C11 Antenna ODU Ø252 mm x 119 mm Height .....	17
Figure 14 – C10 Antenna with Magnetic Mount Component Parts .....	19

## Introduction

This guide provides assistance to personnel installing the Hughes 9300 Series mobile satellite terminal into a vehicle.



### Installation Warning

This product is to be installed by Authorized Service Personnel.

**Note:** Damages resulting in the failure to conform to the instructions found herein, as well as standard installation practices, will be the responsibility of the installer.

## Hughes 9300 Series Mobile Satellite Terminals

The mobile satellite terminals are composed of four core component parts: the transceiver or indoor unit (IDU), the antenna outdoor unit (ODU), the power connector/cable, and an 8 meter RF cable.



**Figure 1 – IDU Common IDU (left), Class 10 ODU (middle), and Class 11 (right)**

The Hughes IDU multiple interfaces that various terminal equipment (TE) devices such as laptops, PDAs, phones, etc., can connect to are Ethernet, ISDN, USB, POTS (RJ11), and wireless LAN (WLAN).

## Indoor Unit (IDU)

The IDU provides all of the TE interfaces, plus the interface for the antenna (ODU), and manages the communications over the Inmarsat BGAN network. Communication to the antenna (ODU) is provided by the RF cable from the IDU.



Figure 2 – Indoor Unit (IDU)

The IDU is equipped with the following ports:

## ***Power Port***

The power port is the connection from the power supply (vehicle battery or some other 12 or 24 VDC power source) to the IDU. The power cable has a +V power line, an ignition sense line, and a -V power line.

<b>Line Type</b>	<b>Pin Number</b>
+V Power Line	1
Ignition Sense	2
-V Power Line	3

**Figure 3 – Power Port Pinout**

## ***Ethernet Port***

### ***RJ 45 Ethernet Port with Power over Ethernet (PoE)***

There is one RJ45 port with Power over Ethernet (PoE) on the IDU. The port supplies standard PoE according to the IEEE 802.3af standard (48 VDC up to 15.4 W) and 10BaseT Ethernet. The pin out of the port supports a direct straight-through connection to a PC with a standard Ethernet cable. The PC will be supplied with a dynamic local IP address using a standard DHCP exchange. Figure 4 shows the pinout of the Ethernet connector.

<b>Pin</b>	
1	RX+
2	RX-
3	TX+
4	+48V
5	+48V
6	TX-
7	-48V
8	-48V

**Figure 4 – Ethernet Port Pinout**

## ***ISDN Port***

There is one ISDN port on the IDU. It provides 4 kbps voice, 3.1 kHz audio, and 64 kbps data communication. The following chart depicts the pinout of the ISDN connector.

<b>Pin</b>	
1	NC
2	NC
3	ISDN RX+(+40V)
4	ISDN TX+(-40V)
5	ISDN TX-(-40V)
6	ISDN RX-(+40V)
7	NC
8	NC

**Figure 5 – ISDN Port Pinout**

## ***RJ11 Ports***

There are two RJ11 ports on the IDU: FAX is for 3.1k fax calls, and TEL for 4 kbps speech calls. The following chart depicts the pinout of the RJ11 connectors.

<b>Pin</b>	
1	NC
2	NC
3	Tip (+V)
4	Ring (-V)
5	NC
6	NC

**Figure 6 – RJ11 Port Pinout**

## ***Antenna Port***

The antenna port is a 50Ω female TNC connector. This line carries the L-band RF, ASK signaling, and DC power (42 VDC) for the antenna.



**WARNING:** The antenna cable carries DC power. Do not connect or disconnect the antenna cable while the unit is powered on.

## ***USB Port***

There is one V1.1 USB client port on the IDU. The IDU has a USB Standard-B receptacle. The USB device appears as an Ethernet device to the user computer and requires a proprietary USB driver available from the Hughes or Inmarsat Web sites.

## ***WLAN Port***

The WLAN port on the IDU is a reverse polarity SMA jack. The supplied antenna is a 2.4 GHz 3dBi “Rubber Duck” antenna with RP-SMA plug connector, part number HG2403RD-RSF.

To prevent blocking or attenuation of the WLAN signal, the IDU should be installed such that there is no metal blocking the radio path to the user’s device.

## ***SIM Card***

The 9350 requires the installation of an Inmarsat SIM. Insert the SIM (supplied by the dealer) into the SIM card holder with the metal contacts facing down. Reinsert the holder and SIM card as shown in Figure 7.



Figure 7 – Inserting SIM Card in the SIM Card Holder

## System Power Requirements

There is one power connection on the IDU. This must be connected to a 12 or 24 VDC power supply.

Power requirements and consumption are as follows:

Voltage Input Minimum	10 V
Voltage Input Maximum	31 V
Total Current for ODU and IDU (max.)	6 A
Required Fuse	$\geq 10$ A

Figure 8 – System Power Requirements

### **Fuse**

The fuse is a 10 A, 5 mm by 20 mm cartridge. The installed part is from Littelfuse, part number 0234010. To replace the fuse, turn the fuse holder anticlockwise with a flat head screw driver and the holder will pop out.

## ***Power Cable***

The power cable uses an Amp 1-178288-3 connector, and the pinout is shown in Figure 9.

<b>Color</b>	<b>Function</b>
Red	DC +
White	Ignition Sense
Black	DC -

**Figure 9 – Power Cable Pinout**

The optional accessory car adapter power cable includes a car adapter plug with a 10 A fuse and the ignition sense wire is connected to the positive power wire in the plug.

## **Standard Cable Connections**

In addition to the DC power connection, an ignition sense connection must be made. This is done using the three-wire power cable. In the case of a vehicle installation, the power source is typically the vehicle battery. Cables should be routed appropriately, and cable ties and clamps should be used as required to ensure that vibration and/or rubbing of the cables does not occur.

### ***Ignition Sense (White Wire)***

Route and connect the white wire (ignition sense) to a switched 12 or 24 VDC source, such as accessory line or fuse block. Extended use of ignition sense in the accessory position (ACC) by the end user may lead to a discharged car battery.

**Note:** Ensure that the connection is a switched source, OFF when ignition is off or in start and ON only when the ignition switch is in the ACCESSORIES or RUN position.

If using the car adapter plug, the ignition sense wire is already connected to the positive power wire in the plug.

### ***Chassis Grounding***

The unit includes an isolating power supply. To ground the IDU in case the grounding provided by mounting bracket is insufficient, connect a grounding wire from the chassis grounding wing nut to the vehicle chassis.



**Figure 10 – Grounding Nut**

## Basic Installation Procedure

While the installation of the Hughes 9300 Series mobile satellite terminal is straightforward, it is essential that the installation be done correctly.

The basic installation procedure is as follows:

1. Decide where you are going to install the antenna and IDU.
2. Ensure that the IDU is located inside the vehicle and attached to something structurally solid. Loose mounts that vibrate will degrade performance.
3. Determine the cable length required for the power installation.
4. Perform the installation of the antenna and IDU.
5. Connect the antenna via the three magnetic mounts to the vehicle's roof or permanently mount using screws/bolts.
6. Connect the RF cable to both the IDU and antenna TNC connectors.
7. Connect the power to the IDU.
8. Properly ground the IDU.
9. Power up the IDU/antenna.

## Vehicular Installation

### *Installation – General*

1. Whenever routing cable through holes drilled in metal or through bulkheads, use grommets and RTV sealant to weatherproof all holes drilled on the outside of the vehicle.
2. Use cable ties every 30–45 cm (12"–18").
3. The IDU can be mounted in either the horizontal or vertical position.
4. The main power line must be connected to a fused 12 or 24 VDC power source. The unit is fused, but a 10 A or greater fuse is required in the source to protect against shorts in the cabling. If connecting to a circuit in the fuse box already in use, ensure that the circuit can supply the extra 6 A at 12 V or 3 A at 24 V for the unit and increase the fuse value by 10 A at 12 V or 5 A at 24 V. If using the car adapter cable, it already includes the fuse in the adapter.
5. Route and connect the white Ignition Sense wire to a switched 12 or 24 VDC source.
6. Ground the IDU to the vehicle via a wire connected to the IDU ground wing nut.
7. Install the IDU in a protected but ventilated area. Allow at least a 1 inch space around all surfaces, except for the bottom surface attached to the vehicle, to provide adequate cooling. Ensure that the location is accessible for servicing.
8. The IDU is not waterproof.

9. Always provision the wiring into the IDU with a drip loop.
10. With the exception of the IDU to antenna RF cable, do not route the power cable outside the vehicle.

## ***Common IDU Mounting Information***

**Note:** Use care when drilling through the body of the vehicle to avoid puncturing critical items.

Instructions for the installer:

1. Mount the terminal onto a flat surface using at least four screws (not supplied). Use screws with a diameter between 3.5 and 4 mm. Vibration resistant screws or lock washers should be used.
2. There are three holes/slots on either side of the base of the terminal for mounting the screws.

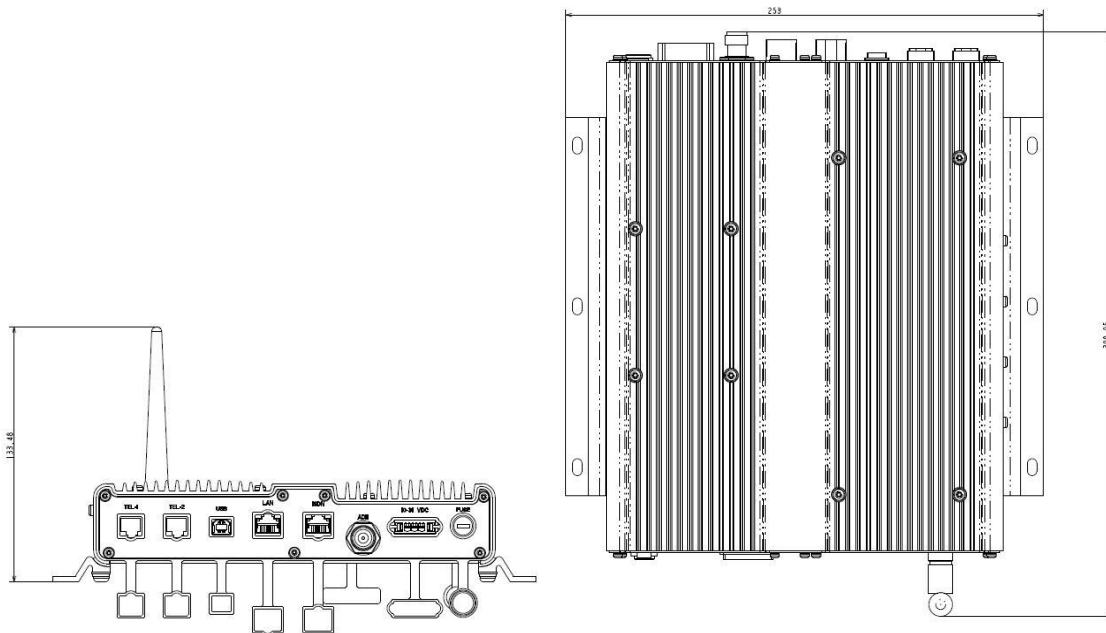

**Figure 11 – Common Indoor Unit Mounting Dimensions**

53 mm x 253 mm x 305 mm without WLAN Antenna  
133 mm x 253 mm x 305 mm with WLAN Antenna



## The Antenna Outdoor Unit (ODU)

The antenna unit is composed of the antenna element, high power and low noise amplifier systems, and a mechanical tracking system.

Both the Class 10 and Class 11 ODUs are two-axis antennas intended for land-mobile use.

Connection to the ODU is made by a TNC connector. The single coaxial cable carries L-band RX and TX, power, and tracking information.



**WARNING:** Only use the C10 antenna supplied with the 9300 Series Terminal. Do not use the similar looking C10EE antenna from a Hughes 9250.



Figure 12 – Class 10 Antenna ODU Ø477 mm X 153 mm Height



Figure 13 – C11 Antenna ODU Ø252 mm x 119 mm Height

## ***Antenna Cable Lengths and Types***

The Hughes IDU has an automatic cable calibration feature that determines the dB loss of the cable. The RF cable that comes standard in the terminal kit is 8 meters long. If a longer cable is required for the installation, the end-to-end RF loss needs to be <10 dB at 1.6 GHz.

**Note:** The installer is responsible for choosing the proper type of cable for the length required in order to meet the <10 dB requirement.

## ***Installing the Antenna***



**WARNING:** Avoid exposure to microwave radiation. Keep a minimum safe distance of one meter (39 inches) to the side and above the antenna.



**WARNING:** The antenna cable carries DC power. Always power the IDU down prior to connecting or disconnecting the antenna cable from either the antenna or the IDU.

The antenna port is a 50Ω female TNC. This line carries RF, signaling, and DC power for the antenna.

Keep a clear line-of-sight to the satellite. Preferably, avoid all obstructions within 3 meters of the antenna. Obstructions less than 15 cm (6 inches) in diameter can be ignored beyond this distance.

It is important to ensure that there is a clear line-of-site to the satellite(s) in all directions. After the terminal is operational, it is recommended that the signal strength be checked while the vehicle is slowly driven in a 360° circle. The signal strength should not vary significantly or be degraded in any particular direction.

Do not locate the antenna close to interfering signal sources or receivers. It is recommended that no other antennas be located within 3 meters of the 9300 Series antennas. If there is other equipment installed near the Hughes 9300 Series mobile satellite terminal, it is recommended to operate all equipment simultaneously and verify there is no cointerference.

## Land Mobile Antenna

### ***Magnetic Mounting (Optional)***

Three magnetic mounts are provided for the antenna installation. These mounts will withstand 100 mph wind force.

If the antenna cannot be mounted using the magnetic feet, the magnetic feet can be removed and the mounting holes can be used to bolt the antenna onto a roof bracket system.

### ***Magnetic Mount Installation***

The magnet mount consists of three individual high intensity magnets with rubber coating. Each magnet has a stainless steel center bolt.

First attach the magnets to the antenna. There are three “legs” on the antenna where the magnets are placed. Note the position of the two rubber washers just below and above each antenna leg, the stainless steel washer above the upper rubber washer, and the protective nut on top.

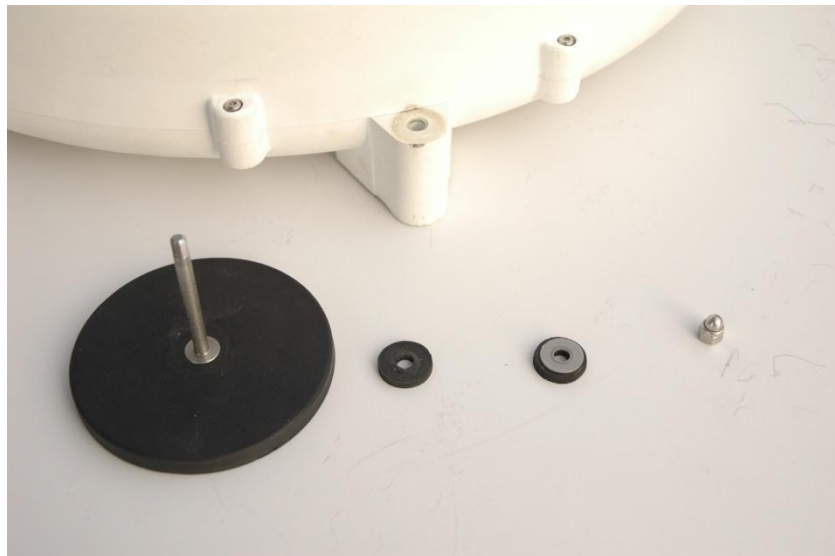

**Figure 14 – C10 Antenna with Magnetic Mount Component Parts**

Next, place the antenna with magnets on the roof of the car. When installing the antenna cable, it is important to protect against moisture by using self-amalgamating or similar

tape wrapped around the coaxial connector. Also be careful with the cable run from the antenna and secure it at short intervals. An unsupported length of cable will vibrate when driving and could negatively affect the connection over time.

## ***Dismounting the Magnetically Mounted Antenna***

Use your hand to pry underneath the antenna near one of the magnets and lift. When one magnet is loose, the other two easily break off.

## ***Permanent Mount Installation***

When permanently installing the antenna on vehicles, some important guidelines must be followed in order to ensure long and trouble free operation.

Not following these guidelines will void the warranty of the antenna. If in doubt, please consult SpaceCom at [spacecom@spacecom.dk](mailto:spacecom@spacecom.dk) or call (+45) 98511576, Service Department.

- 1. Always install the antenna so that it is in a horizontal position, even if the surface on which it is installed e.g. roof of a vehicle, is not horizontal.**

The antenna has three drainage holes at the bottom.

- 2. Always install the antenna so that clearance between bottom of antenna with drainage holes and mounting surface is no less than 5 mm and preferably 10 mm, refer to Fig.2.**

In order to fulfill the above criteria 1 and 2, a set of bolts and washers has to be defined for each individual installation; refer to Fig.1.

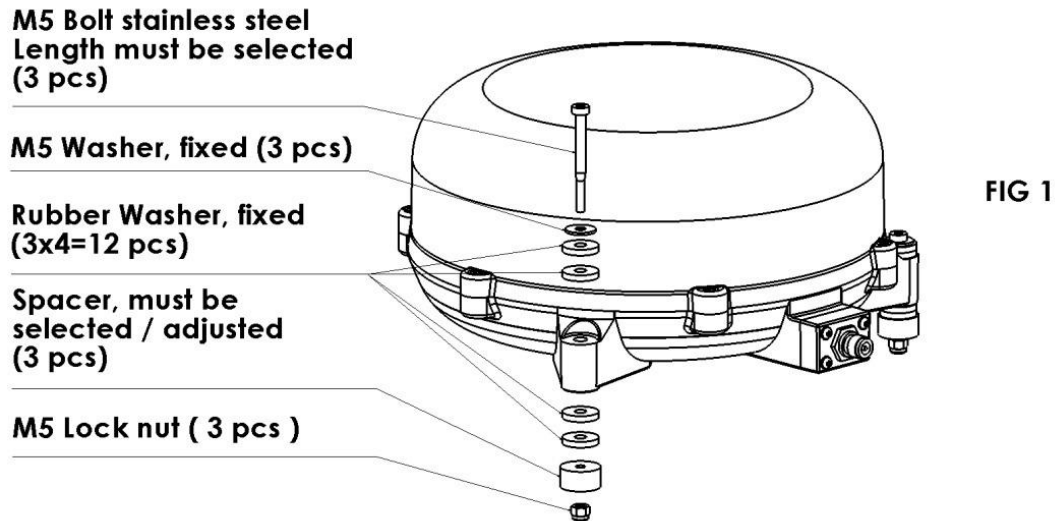

The M5 stainless steel washers are **always** used and **positioned** as shown in Fig.1. The rubber washers are **always** used and **positioned** as shown in Fig.1. The spacers are **always** used and **positioned** as shown in Fig.1.

The 3 spacers will have identical length if the antenna is installed on a non tilting surface, but may require individual length adjustment if the surface is tilting. The M5 stainless steel bolts will have identical length if the three spacers are identical and may require individual length adjustment if spacer length are different.

An Installation Kit is included with every antenna. It contains the washers that are always used, three standard 10 mm spacers used for a typical installation on a non tilting surface and standard length M5 stainless steel bolts with nuts – **Note** length may have to be adjusted to accommodate a tilting surface.

Additional Installation Kit's are available from SpaceCom Part No.: SPAC-AC-1036 Installation Kit.

### Drainage of the antenna

In order to keep the height of the antenna as small as possible and in order to avoid the complex and often unreliable complete sealing of the antenna a simple mechanism in the form of three holes in the dome (plastic enclosure) bottom is used. The holes are made so that water e.g. solid drops is not likely to enter the dome and simultaneously water that incidentally has entered the dome or moisture condensed in the dome is drained out simply by gravity. Correct function of the drainage system will only be ensured by following criteria 1 and 1 above.

Tighten M5 screw so that the four rubber washer are compressed 2 mm altogether

Spacer, must be selected / adjusted

M5 Lock nut  
( Use only nuts that have active retain function )

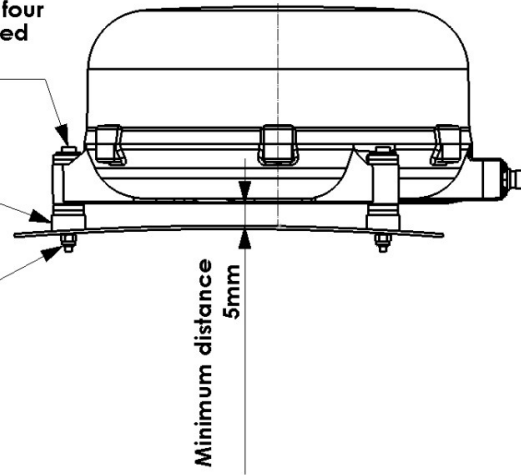

FIG 2

## Extreme Conditions

A supplementary kit, that enhances the robustness against splashing water from any direction and improves robustness against dirt and dust in very harsh environments, is available from SpaceCom. This kit will however increase the total height of the antenna by 15 mm. Criteria 1 and 2 still have to be fulfilled. Part No.: SPAC-AC-1025 - Water lock for radome.