

HUGHES
NETWORK SYSTEMS



Service and Revenue Delivery Opportunities Using Broadband Wireless Access

January 2003

A White Paper for Telecommunications Service Providers Using the AIReach® Broadband 9000 System

This AIReach Broadband White Paper outlines some of the service delivery and revenue generation opportunities for telecommunications service providers taking advantage of AIReach® 9000 for broadband wireless access (BWA) networks. AIReach 9000 is a highly advanced, next-generation, point-to-multipoint (PMP) system (these are often also called LMDS systems). It is the result of Hughes Network Systems, Inc. 30 years of unparalleled experience in radio-based communications systems, transmission control, spectrum management, and network service operations. The source of customer service and revenue creation opportunities lies in the AIReach 9000's unique product advantages of spectrum utilization, bandwidth management, and system management.

1.0 Background

Although there are wide variations in scale, telecommunications networks invariably are structured in layers. The first layers of a typical network are shown in **Figure 1-1**.

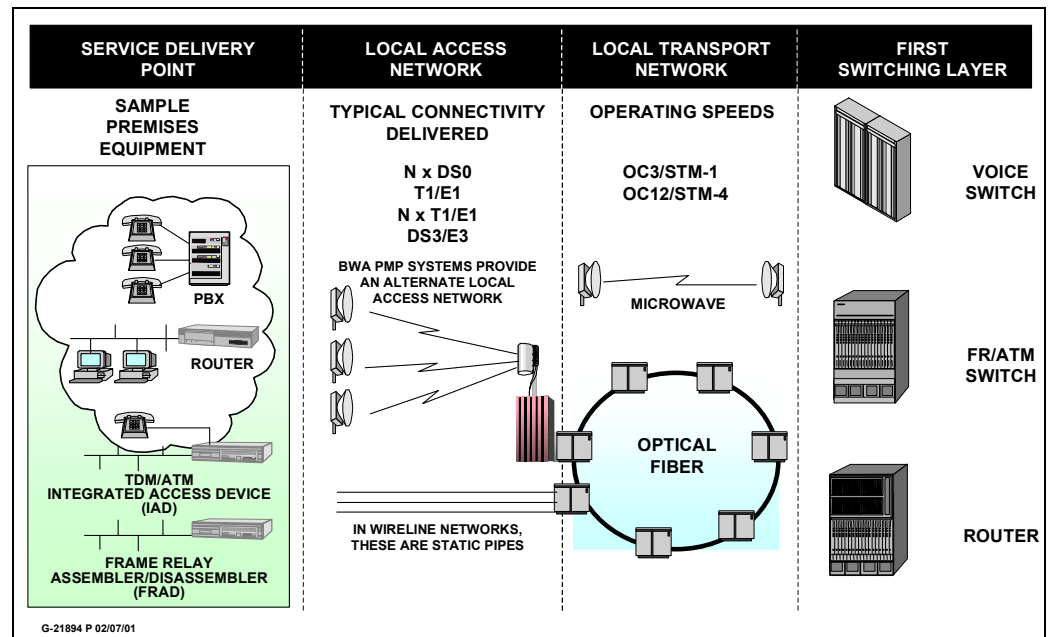

Figure 1-1. Layers in a Metropolitan Area Telecommunications Network

On the left side of **Figure 1-1**, the premises equipment at the point-of-service delivery may be provided by customers themselves or by service providers. The latter may provide this equipment as an extension of the network itself or as value-added service to the customer, as in managed customer equipment. In either case, this equipment is often essential to a particular service, for example, in equipment-based virtual private networks (VPNs).

The next layer—the local access network—is the focus of this White Paper. It has the most impact on service delivery and creation, and it is the layer where BWA systems offer a

“...a key shortcoming of a wireline deployment is the static, inflexible nature of its connectivity.”

compelling alternative to a wireline approach. Besides the enormous time consumed and costs of deploying a wireline local access network, a key shortcoming of a wireline deployment is the static, inflexible nature of its connectivity. All user traffic is constrained to the “pipe

size” of the circuit. By contrast, an AIReach 9000 local access network inherently can make a large pool of bandwidth available to all customers. This flexibility is a distinct advantage in meeting the “what and when” of customer demand.

The local transport layer delivers the traffic collected by the local access network to the first switching layer. This layer often runs on optical fiber, but point-to-point microwave links have a role as well. In some instances, this layer may not be present.

The rightmost layer in **Figure 1-1** is where the first network switches are located. Note that ATM is commonly used as an underlying network transport mechanism by virtue of its ability to carry constant and variable rate traffic—loosely related to voice and data.

2.0 Providing What Customers Want

In this section we will explore the role that AIReach 9000 plays in allowing you, as a service provider, to offer the key services that customers want. We will look at private line options, a variety of data services, including Internet access or services using the Internet and voice services. We will see that AIReach 9000 allows you to meet customer needs in ways that meet and often exceed those options that are available via a wireline infrastructure.

2.1 Private Line Services

By definition, a private line delivers a constant, predictable communications channel between two endpoints (i.e., *through* the network). A subset of private line is a point-to-network configuration, which is typically a channel to a voice or data switch in the network.

Private line services remain a mainstay in a carrier’s service portfolio, and your customers expect these to be offered. Here is an initial example of how AIReach broadband will enable

AIReach broadband enables you to offer unique alternatives... with...private lines.

you to meet and exceed these expectations by offering unique alternatives. As customers expect—and as are available with many wireline networks—the AIReach product lets you deliver

private lines from DS0 (56/64 kbps) all the way to 30 or 45 Mbps. *Here is where you gain the advantage:* freed from wireline constraints, AIReach broadband enables you to offer these lines at virtually any rate in between. Furthermore, since AIReach broadband’s AIRfill™ Dynamic Bandwidth Allocation system is dynamic, these private lines can be provisioned *on demand* – even at unusual rates, *even* for short time periods.

Private lines are applied in many ways. Common applications include tie-line trunking between PBXs; host-to-host, host-to-storage, LAN-to-host connections; and LAN-to-LAN connectivity.

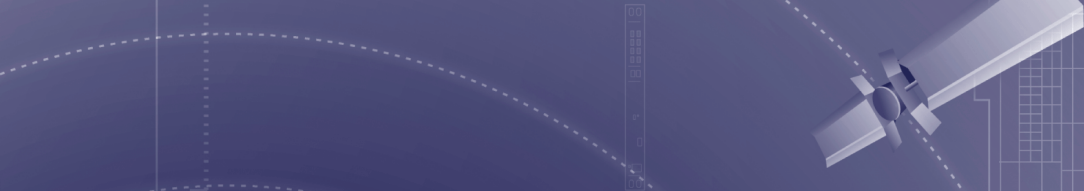

For an emerging service provider, the capability to offer switched (on-demand) private lines opens up many new bandwidth-on-demand (BOD) applications such as distance learning, video-on-demand, and telemedicine. Serving these needs is one way to stand out in your market.

2.2 Data Communications Services

Although the dominant topic in carrier data communications services today remains the Internet, enterprise LAN (local area network) interconnect (sometimes described as intranet connectivity) is also highly in demand. Both may be offered to your advantage using AIReach® products and services.

Intranet connectivity often uses frame relay at layer 2 (the frame layer). Most applications written today use Internet Protocol (IP) at the network layer (layer 3), but many other protocols are also used. One reason that frame relay is so popular in the wide area intranet is the ease with which it carries all these protocols. In addition, frame relay inherently offers high security and easily meets QoS (quality of service) targets. AIReach Broadband enables you to tap into this market. It supports frame relay-based connectivity up to T1/E1 speeds.

Like frame relay, asynchronous transfer mode (ATM) may carry any number of protocols and offer security and QoS. As a user interface, ATM has been more generally applied for higher speed (e.g., 45 Mbps) connections. AIReach supports ATM connections at speeds up to 45 Mbps. With intranet services, it is common that a headquarters location has a high-speed ATM connection to the network, but that its field locations are connected using frame relay at speeds up to T1/E1. In this arrangement, the network must support the FRF.8 standard, which governs frame relay/ATM interconnectivity. AIReach supports FRF.8 as well as the FRF.5 standard. The latter governs frame relay transport (frames in, frames out) over an ATM infrastructure.

Frame relay and ATM are two options that AIReach offers for intranets or even local access to the Internet. However, AIReach also supports transparent or clear channel connections through the local access network.

Many leading-edge service providers employ an ATM infrastructure. Those using AIReach Broadband often use an ATM IAD (integrated access device) or a multiprotocol router as the

“...service providers can deliver on the promise of broadband data communications... and provide a large amount of bandwidth for a short amount of time.”

point of interface or demarcation with their customers. In doing so, they can offer a high-speed (e.g., 10/100 Mbps ethernet, 45 Mbps DS3) interface to the customer and to the AIReach network. In this way, these service providers can deliver on the promise of

broadband data communications, i.e., the ability to dynamically draw on a bandwidth pool and provide a large amount of bandwidth for a short amount of time. As a result, customers have bandwidth floors, not bandwidth ceilings. Only a broadband wireless LAN with the power and flexibility of AIReach broadband can deliver on this promise. By contrast, as discussed above, wireline networks inherently impose a low ceiling, constraining user traffic to the pipe size of the circuit.

Extranet connectivity is often used to describe access to the Internet or even using the Internet to provide “virtual private intranets.” With the Internet having become the universal means to conduct business-to-business communications, demand for Internet access is very strong. With AIReach Broadband, not only are you able to provide the necessary local

access network connectivity but, as discussed above, by using high-speed connections to the customer, you can take advantage of AIReach bandwidth management and allocation capabilities to dynamically offer large bandwidths to accommodate traffic bursts.

Customers need and demand a variety of other data communications services, e.g., VPNs using the Internet, service provider-managed customer premises equipment, Web hosting, or application hosting. In all of these, AIReach Broadband is either neutral—i.e., it supports the requisite local access network connectivity—or, through its flexible connectivity options and bandwidth sharing arrangements, the AIReach product provides distinct advantages over wireline-based alternatives.

2.3 Voice Services

Today, voice traffic is commonly carried in the local access network as a DS0 channel within a T1/E1 circuit. AIReach Broadband supports this traffic as in any local access network. (In fact, *transparent* to the customer, AIReach Broadband can carry these T1/E1s in a TDM mode or in ATM cells. Each offers some advantages to the service provider.)

Integrated access devices (IADs) are increasingly being used to compress and convert voice traffic to ATM cells without sacrificing quality. This compression conversion allows bandwidth efficiency in the local access network and the ability to seamlessly mix voice and data traffic. For a service provider using a cell-based local access network such as AIReach Broadband, this development is promising.

As voice-over-IP gains momentum, the advantages for a cell-based infrastructure will increase in the face of giant shifts away from the TDM infrastructure.

2.4 Available Service Offerings

The service offerings available using AIReach Broadband and a conventional wireline access network are summarized in **Table 2-1**. The conclusion is that an AIReach BWA network may not only support all of the services delivered by a wireline network, but that AIReach Broadband may further support distinct alternatives.

Table 2-1. Service Offerings

AIReach Broadband: Everything and More	AIReach BWA Network	Wireline Access Network
Private Line/Point-to-Network		
N x DS-0	✓	✓
T1/E1	✓	✓
Up to 45 Mbps	✓	
Switched Private Line	✓	
Data Services		
LAN Interconnect	✓	✓
Internet Access	✓	✓
Voice Services		
via Point-to-Network	✓	✓

These alternatives are depicted in **Figure 2-1** and **Figure 2-2**. The former shows services supported directly from the AIReach system, while the latter indicates the additional service offerings that arise with the addition of provider-owned customer premises equipment.

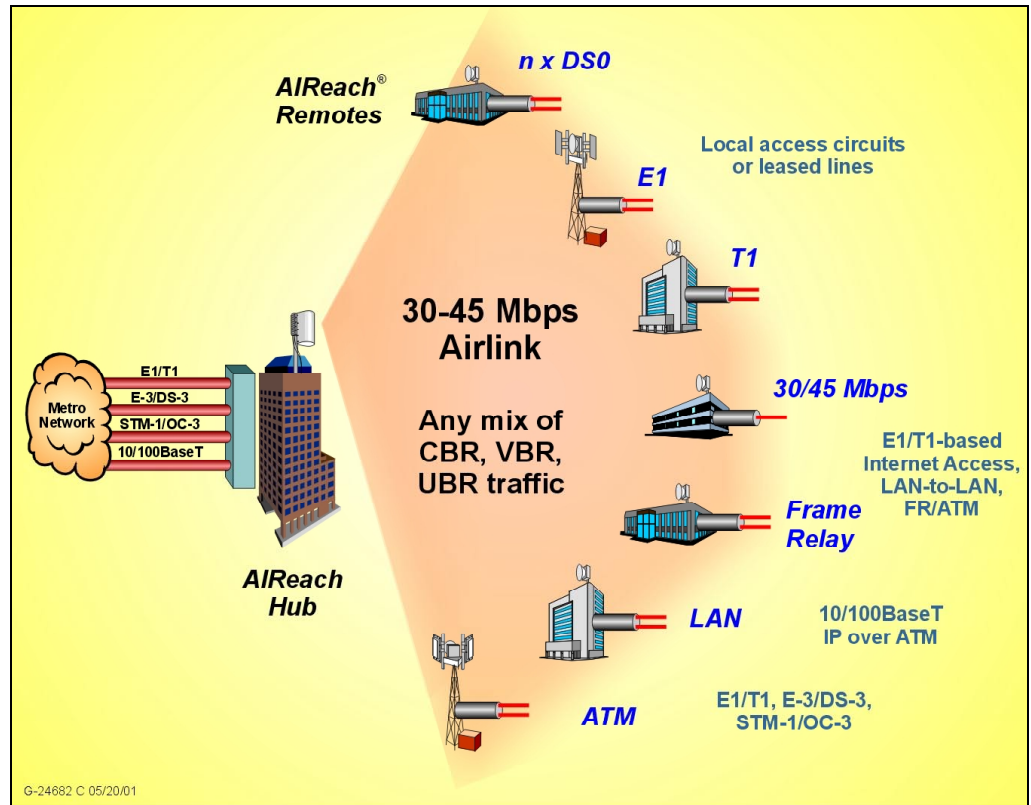

Figure 2-1. Delivering Proven, Revenue-Generating Services Directly from AIReach System

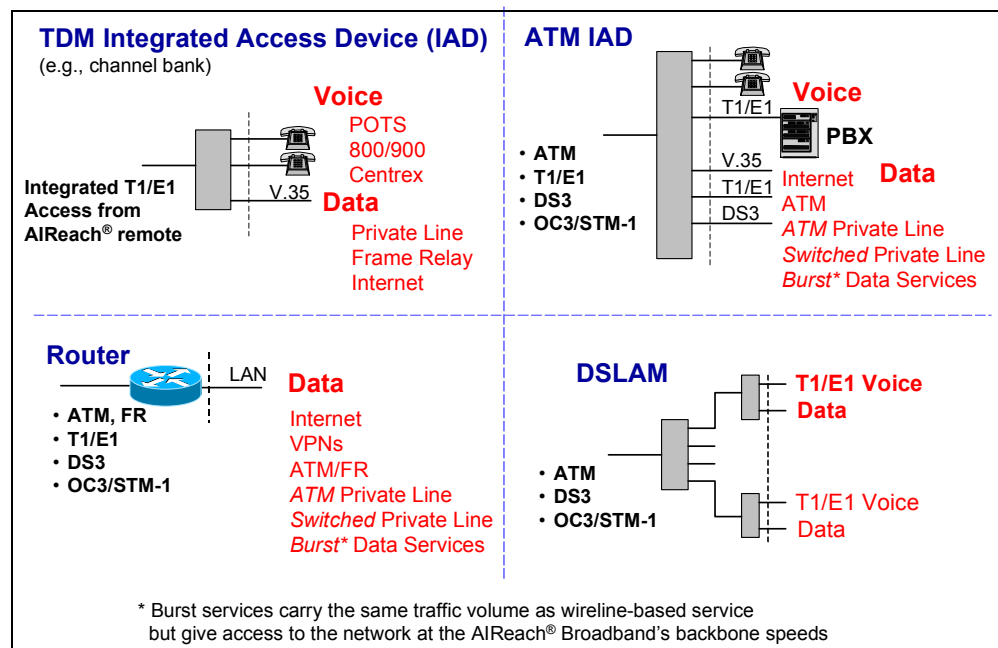
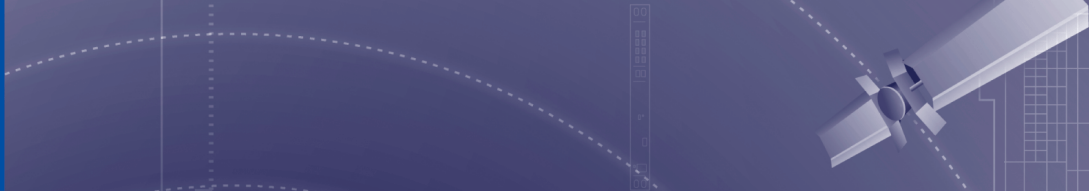

Figure 2-2. Adding CPE Creates Additional Revenue-Generating Opportunities



We have just examined how an AIReach--powered local access network enables you to offer everything that a wireline local access network can—and more. Now, let us look at the fulfillment side of an offering.

3.0 The Other Part of Winning—Providing It When They Want It

To service the needs of a customer, your network must be able to fulfill requests at specific locations at specific times. Therefore, whether or not you have a wireless access network, the first issues are coverage and availability. In the case of a BWA network, the questions are whether the customer is within your coverage area and whether sufficient capacity is available and accessible.

The first issue, coverage, is largely driven by the range of your system. To extend range and coverage, AIReach Broadband has a capability called *AIRmatch*[™] Dynamic Modulation Matching. With this capability, customer locations distant from the AIReach Broadband hub might be served by the quadrature phase-shift keying (QPSK) modulation, while mid-distant

“...*AIRmatch* technology allows modulation to be matched to the immediate needs of a *specific* site...”

sites might be served by more spectrally efficient 16-QAM modulation and nearby sites might be served by the ultra-efficient 64-QAM modulation. Since the *AIRmatch* technology allows modulation to be *matched* to the needs of a *specific* site, you do not have to

completely trade off capacity (spectral efficiency) for range and coverage. Therefore, the AIReach system allows your system to operate at high capacity without being range-limited. This combination lets you fulfill customer need where you find it. If this is “picking the low-hanging fruit,” then think of AIReach Broadband as a basket-filler.

Beyond coverage, the other part of meeting customer needs is the ability to provide the *specific* service being requested. In other words, sufficient system capacity is available and usable. In BWA networks, the availability of capacity relates mainly to bandwidth or

“*AIRmatch*...with *AIRfill* managing capacity, greatly increases the chances of having capacity available when your customers demand it.”

spectrum management. BWA systems typically offer a high order modulation such as 64-QAM for spectrum efficiency or a spectrally inefficient one like QPSK for greater range/coverage area. The network operator must choose which to use. With *AIRmatch*

matching, there is no choice required – you can have both range *and* capacity. Sites far from your hub may operate with QPSK or 16-QAM all of the time; nearby sites may operate with 64-QAM all of the time, and sites in between may operate with any of the three, depending upon need. *AIRmatch* matching is the most efficient means to manage your spectral resource, and, in conjunction with *AIRfill* managing capacity, greatly increases the chances of having capacity available when your customers demand it.

In the *Providing What Customers Want* section, we discussed AIReach broadband’s flexibility in making bandwidth available to users. This is also a delivery issue—one of making service available immediately—for example, being able to immediately provision private lines at a variety of rates, even for short time periods.

4.0 Summary

This AIReach Broadband White Paper has shown how employing the AIReach Broadband 9000 for your BWA network lets you provide all of the telecommunications services demanded by users from their wireline network operator. It also demonstrates how AIReach Broadband lets you provide services that are in demand but that have been unsupported until now.

We have further discussed certain features of the AIReach product, most notably its *AIRmatch* Dynamic Modulation Matching and *AIRfill* Dynamic Bandwidth Allocation features, and how they work together to provide range and capacity, greatly increasing the chances of immediately accommodating a customer requirement for service.

AIReach[®], *AIRmatch*[™] Dynamic Modulation Matching, and *AIRfill*[™] Dynamic Bandwidth Allocation, are registered trademarks of Hughes Electronics Corporation (HUGHES).